

**REPORT NAME: KIT PFS-16104  
INSTALLATION INSTRUCTIONS AND  
INSTRUCTIONS FOR CONTINUED  
AIRWORTHINESS**

**APPROVAL**

**PFS ENG**

**DATE: 02/16/2006**

**REPORT NUMBER: PFS-16250-EXP**

**REVISION: A**

**REPORT DATE: 02/14/06**

**PREPARED BY: Tom Strohmayer**

For Experimental Aircraft Only:  
Glastar, Sportsman 2+2, and Similar with  
Lycoming O320 or O360 Parallel Valve Engines

Design Protected Under One or More of the Following U.S. Patents:  
6,581,376; 6,374,599; Additional Patents may be Pending.

## **Revision Control Page**

### **REPORT PFS-16250-EXP Kit PFS-16104**

<b>REVISION</b>	<b>DATE</b>	<b>REMOVE PAGES</b>	<b>INSERT PAGES</b>
<b>IR</b>	<b>10/27/05</b>	<b>N/A</b>	<b>N/A</b>
<b>A</b>	<b>02/14/06</b>	<b>5,7</b>	<b>5,7</b>

# **TABLE of CONTENTS**

## **PFS-16104**

<b>Section</b>	<b>Page</b>
<b>Introduction</b>	<b>4</b>
<b>Kit Contents</b>	<b>5</b>
<b>Preparation</b>	<b>6</b>
<b>Removal of old exhaust system</b>	<b>6</b>
<b>Installation</b>	<b>6</b>
<b>Installing Collector Box assembly and Exhaust pipes</b>	<b>6</b>
<b>Installing the Tailpipe Assembly</b>	<b>7</b>
<b>Completing the Installation</b>	<b>7</b>
<b>Instructions for Continued Airworthiness</b>	<b>8</b>
<b>Troubleshooting</b>	<b>9</b>
<b>Removal</b>	<b>9</b>
<b>Inspection</b>	<b>9</b>
<b>Installation Overview</b>	<b>11</b>
<b>Detail “A”</b>	<b>12</b>
<b>Detail “B”</b>	<b>13</b>
<b>Detail “C”</b>	<b>14</b>

## **Introduction**

**Note:** PFS is the abbreviation for Power Flow Systems, Inc.

**Description:** The PFS exhaust consists of an exhaust pipe from each cylinder to the collector assembly located beneath the engine. The collector assembly is enclosed in a shroud, which captures ram air from the engine compartment baffle to be heated by passing around the collector assembly's inner tubes. This heated air is used to heat the aircraft cabin. A separate compartment of the collector assembly furnishes heated air for carburetor heat. A tailpipe from the collector assembly routes exhaust gases to a muffler through the rear of the engine compartment. Additional parts are supplied to fabricate an exhaust hanger assembly.

***Please read these directions completely before starting installation.***  
**Please call us at 386-253-8833 during normal business hours if you have any questions regarding the installation of this kit.**

**Please Note:** The Power Flow Systems Exhaust has been designed to be installed in accordance with these instructions. Any modification to the exhaust system or its components, or any deviation from these instructions without express written permission from Power Flow Systems, Inc. invalidates the design and therefore the exhaust system warranty.

\*\*\*\*\*PLEASE READ\*\*\*\*\*

To maximize the life expectancy of your new Power Flow Systems Tuned Exhaust, it is highly recommended that you dynamically balance your propeller to below 0.2 ips. Please understand that a new engine and/or new propeller do not guarantee proper dynamic balance. Propellers are statically balanced by the manufacturer/overhauler. Engines may be balanced by the manufacturer or overhauler. The only way to dynamically balance your combination is to do so after the propeller has been installed on the engine. A vibration of greater than 0.2 ips can diminish the life expectancy of electronic components, baffling, engine mounts, etc., as well as your new exhaust system. Just because your combination "feels" smooth, does not mean it is balanced.

\*\*\*\*\*

## Kit Contents

*Each Power Flow exhaust kit is shipped with:*

4 Headers	PN: 11600, 12600*, 13600, 14600*
4 No-blow Header Gasket	PN: 77611
8 Exhaust Nut	PN: SL-STD-1410 (or Stainless Equivalent)
8 Lock Washer	PN: MS35333-41
8 Plain Washer	PN: AN960-516
1 Shrouded Collector Assembly	PN: 41602
1 Muffler Assembly	PN: 80060 (-CER)
3 Drilled Bolt	PN: AN3C12
3 Castle Nut	PN: AN310C3
6 Flat Washers	PN: AN960C10
3 Ball Joint Springs	PN: 33703
4 Cotter Pin	PN: MS24665C153
12" SCAT Tube	PN: SCAT-8
1 Muffler Clamp	PN: 8031
1 Drilled Bolt	PN: AN4C5
1 Castle Nut	PN: AN310C4
2 Flat Washer	PN: AN960C416
1 Reducer, 2.0 to 1.5	PN: 6587
1 Angle Adapter	PN: 6588

\*Lycoming O320 Engines Use 12600-1 and 14600-1 Headers

EQUIVALENT HARDWARE MAY BE SUPPLIED THROUGHOUT

## PREPARATION

**Verify that all contents listed on page 5 of this instruction set are included in your kit. Read all instructions before attempting installation, to become familiar with the procedure. If you have any questions regarding the installation, please call (386) 253-8833 before attempting installation.**

## REMOVAL OF OLD EXHAUST SYSTEM

(If Applicable)

- 1) Remove engine cowlings in accordance with the current Aircraft Service Manual.
- 2) Disconnect flexible ducts from muffler assembly and exhaust pipe.
- 3) Remove EGT probe(s), if installed.
- 4) Remove nuts, bolts, and clamps attaching tailpipe to the tailpipe hanger.
- 5) Loosen nuts attaching exhaust pipes to cylinders and remove muffler assembly.
- 6) Remove exhaust pipes and gaskets.

## INSTALLATION OF PFS EXHAUST SYSTEM

*NOTE: If you are installing EGT probes, we recommend locating and drilling the holes for the probes in the headers in accordance with the latest approved revision of the Aircraft Service Manual. If a Service Manual is not available, we recommend between 2 and 4 inches from the exhaust port. Be sure to use the same measurement for each probe.*

### A. Installing Collector Box Assembly and Exhaust Pipes:

*NOTE: Each header and collector is marked with its appropriate cylinder number – make sure that each header installed matches the correct collector location.*

- 1) Insert headers into the collector box according to the numbering on the headers and collector box.
- 2) The header pipes must be installed at least 1 1/2" into the collector assembly. Align each header with the factory's alignment marks to ensure correct orientation and adequate installation depth. Remove the alignment labels.
- 3) Put new exhaust gaskets into position on each cylinder. It is suggested that you keep them in place temporarily with either a loop of safety wire or a large cotter pin. Lift and hold the assembly into position.
- 4) Install a washer, a lock washer and a nut on each stud (there are 8 sets of these). If utilized, remove the loops of safety wire or cotter pins. **See Detail "A."** Torque the exhaust nuts to final torque after proper orientation and assembly position of the exhaust system is achieved. Use the torque recommended in the latest approved revision of either the Aircraft or Engine Service Manual. (Generally 200 in-lbs)

Power Flow Systems, Inc. Extractor Exhaust Installation Instructions  
Kit: PFS-16104

**B. Installing the Tailpipe:**

- 1) Using the hardware provided, assemble the ball joint. **See Detail “B”**. The compressed spring height on the ball joint should be between 0.430 and 0.475” add or remove washers as necessary.
- 2) With the large clamp free from the hanger, the lower end of the muffler assembly should be able to 'wobble' 1/2" to 1 1/2" from side to side.

**CAUTION**

**Over-tightening the ball joint assembly may cause cracking in the 4 to 1 collector and damage to the ball joint assembly.**

- 3) Attach the muffler assembly to exhaust hanger with muffler clamp P/N 8031. **See Detail “C”**. An exhaust hanger may be fabricated from any non-rigid material joining the muffler clamp to the tubular engine mount or firewall. We recommend neoprene coated fiberglass or a high temperature, high strength hose. Position the clamp as necessary for attaching to the tailpipe hanger. A minimum of 1/2” clearance should exist between the tailpipe and any cowling or airframe components.

**C. Completing the Installation**

- 1) Attach all flexible tubing to the collector box.
  - a. Carb heat attaches to the most passenger side tube (the one with the screen under it).
  - b. Cabin heat IN attaches to the pilot side end of the collector box.
  - c. Cabin heat OUT attaches to the tube slightly to the pilot side of the carb heat tube.
  - d. Use reducers and adapters as required for clearance and fit.

Typical Weight and Balance Information: The Power Flow Exhaust system weighs approximately 17.5lbs.

## **INSTRUCTIONS FOR CONTINUED AIRWORTHINESS**

**It is the responsibility of the aircraft owner/technician to ensure that the most recent revision of these instructions is followed. The most recent revision of this report can be obtained by calling Power Flow Systems, Inc. at (386) 253-8833 or online at [www.powerflowsystems.com](http://www.powerflowsystems.com)**

### **1.0 BASIC OPERATION**

Basic operation of the airplane remains the same. The pilot must watch to ensure that redline of the RPM is not exceeded.

### **2.0 AIRWORTHINESS LIMITATIONS**

- 2.1 Mandatory Replacement Time – None. Any collector assembly that is damaged and/or fails the pressure test described below must be replaced.
- 2.2 Structural Inspection Interval – At 100 hour or Annual intervals, depending on the service regime of the aircraft. **WARNING: Carbon Monoxide gas present in exhaust gases can lead to pilot incapacitation and/or death. A damaged exhaust system has the potential to allow Carbon Monoxide into the aircraft cabin. To prevent such an occurrence, it is imperative that the exhaust system is inspected using the intervals and procedures described in this report. It is recommended that in-cabin carbon monoxide levels be measured periodically. Concentrations of greater than 50ppm will require immediate exhaust system repair or replacement.**
- 2.3 Structural Inspection Procedure – See Section 5.0 Below.

Power Flow Systems, Inc. Extractor Exhaust Installation Instructions  
Kit: PFS-16104

### 3.0 TROUBLESHOOTING

<b>Problem</b>	<b>Possible Cause</b>	<b>Solution</b>
Exhaust smell in cockpit	Exhaust Leak	Immediately inspect exhaust system for leaks, <b>do not return to service until problem is resolved.</b>
Excessive vibration	Collector not centered on header pipes	Reposition collector -- ensure minimum of 1 1/2" penetration per header into central collector system
	Ball Joint too Loose	Tighten Ball Joint
	Broken Exhaust Hanger	Replace Exhaust Hanger
Excessive noise	Propeller not properly balanced	Have propeller dynamically balanced
	Muffler insert damaged or missing	Contact PFS, Inc. for new muffler insert

### 4.0 REMOVAL OF PFS EXHAUST SYSTEM

- A) Disconnect muffler clamp P/N 8031 from the exhaust hanger. Remove clamp.
- B) Disconnect the ball joint assembly.
- C) Remove EGT probes if installed.
- D) Disconnect flexible ducts from the collector assembly.
- E) Remove nuts and washers attaching headers to exhaust ports.
- F) Remove the collector assembly.

### 5.0 INSPECTION

The exhaust system must be thoroughly inspected, especially within the heat exchanger section. A detailed visual inspection of the exhaust system must be performed in accordance with the latest revision of the Aircraft Service Manual at either 100 hour or annual intervals.

All components displaying cracking or general deterioration must be replaced with new parts or repaired in accordance with the latest approved revision of AC 43.13.

- A. Check for holes, cracks, and burned spots. Especially check areas adjacent to welds. Look for exhaust gas deposits in surrounding areas. Look for unusual tube discoloration. This may indicate an exhaust leak.
- B. Inspect screen covering carb heat outlet. Screen must be secure with no risk of material falling off.
- C. Inspect packing material in the muffler body. If the packing is missing or deteriorated, it will require replacement. New packing inserts are available from Power Flow Systems, Inc.

Power Flow Systems, Inc. Extractor Exhaust Installation Instructions  
Kit: PFS-16104

- D. Inspect for ball joint freedom of movement by disconnecting the exhaust hanger. The muffler should be free to move by applying minimal force. If the muffler isn't free to move:
1. Disassemble the ball joint and inspect for surface abnormalities such as galling or wear marks.
  2. Rework the ball joint as required to correct noted discrepancies.
  3. Reassemble the ball joint. Do not over tighten the clamp as this may distort ball surfaces.
- E. **Be sure to remove shroud to inspect within the collector assembly.** If the integrity of any surface is suspect, proceed as follows:
- F. If any defects on the collector assembly (other than on the shroud) are noted during the visual inspection, then the collector needs to be pressure tested using the procedure below:
1. Remove shroud.
  2. Seal four of the openings (tubes) with rubber expansion plugs.
  3. Submerge the collector assembly in water.
  4. Using a manometer or pressure gauge, apply 3.0 to 3.5 PSI (approximately 7" Hg) of air pressure to the fifth opening.
  5. Let the unit sit pressurized for 10 to 30 seconds. The leak rate should be zero.
  6. If a leak is found in the collector assembly, replace before further flight.
  7. If no leaks are found, dry components and install on airplane, lube all slip joints with anti-seize before installation.

# INSTALLATION OVERVIEW

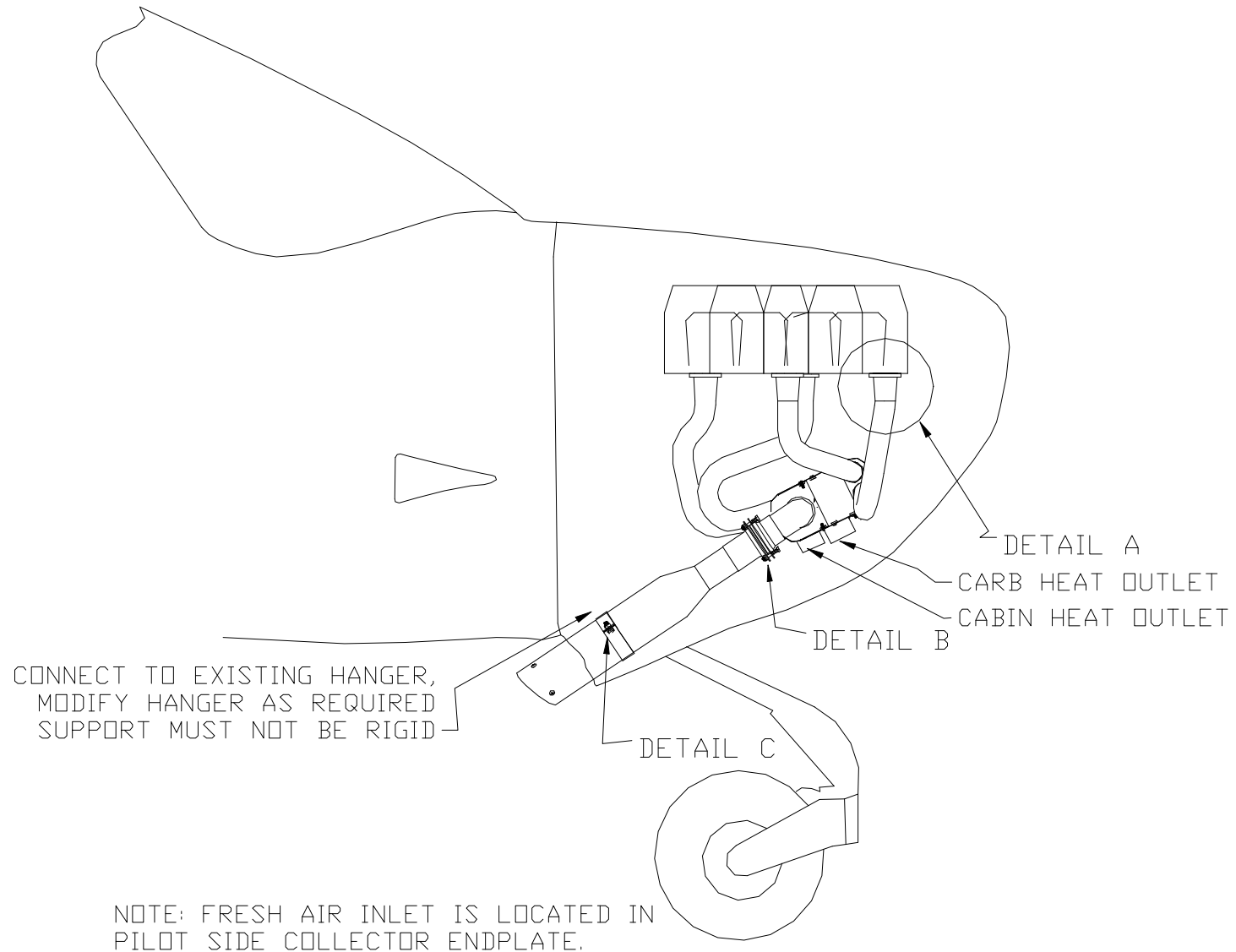

# Detail "A"

- |   |                |                 |
|---|----------------|-----------------|
| 1 | Exhaust Stud   | Lycoming Engine |
| 2 | No-Blow Gasket | 77611           |
| 3 | Flat Washer    | AN960-516       |
| 4 | Lock Washer    | MS35333-41      |
| 5 | Nut            | SL-STD-1410     |
| 6 | Header         | Various         |

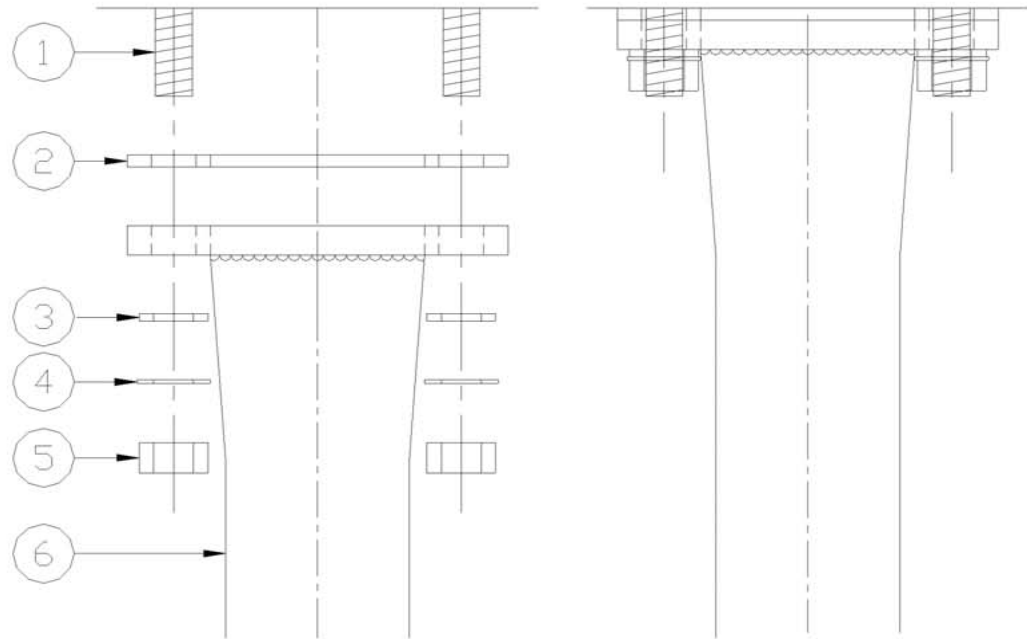

Note: Equivalent Stainless Steel Hardware may be substituted.

Rev A 06/05/02

Power Flow Systems, Inc. Extractor Exhaust Installation Instructions  
Kit: PFS-16104

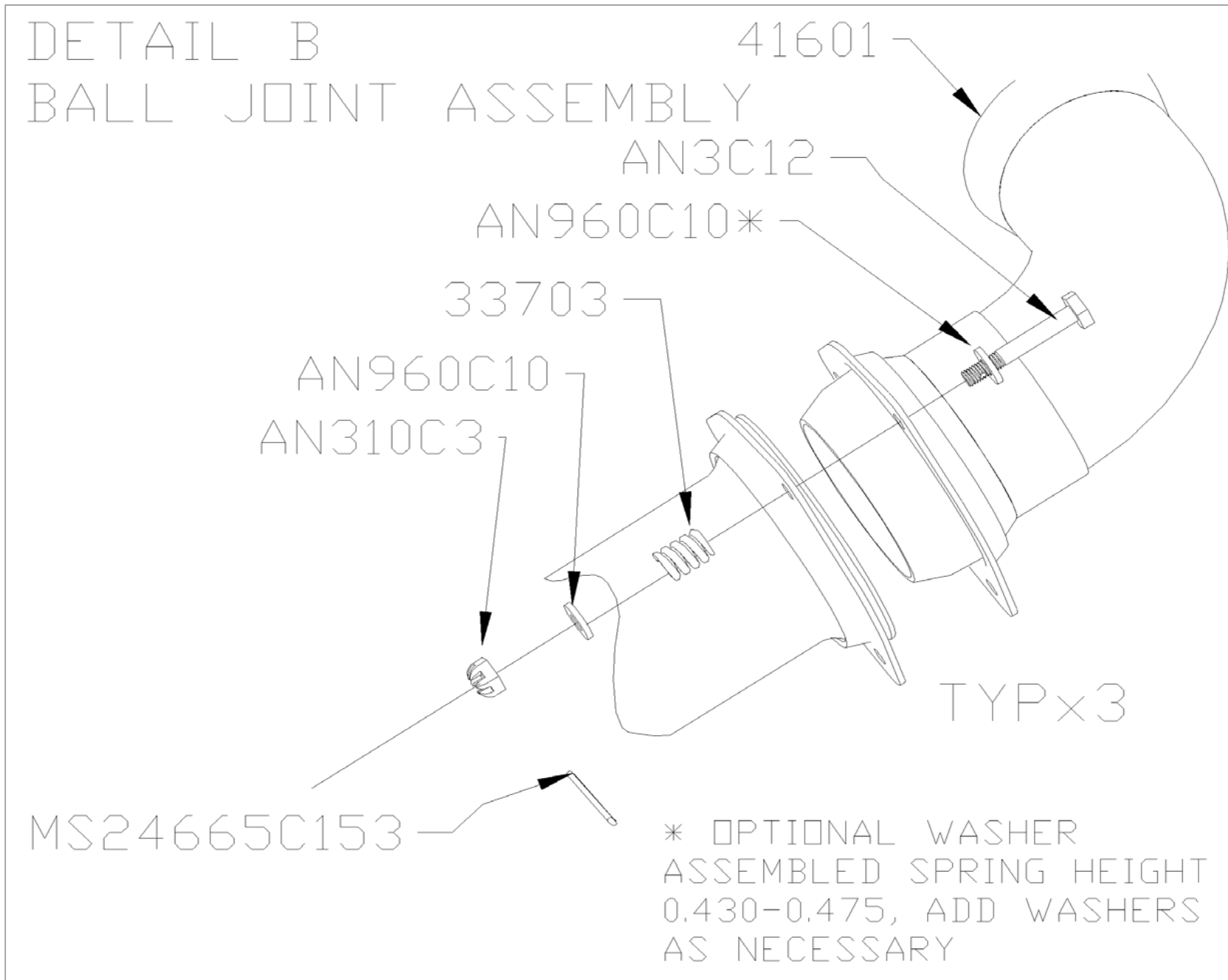

Power Flow Systems, Inc. Extractor Exhaust Installation Instructions  
Kit: PFS-16104

